

Technical Data Sheet

Drum pumps F/FP 424



More than just pumps

Drum pumps F/FP 424

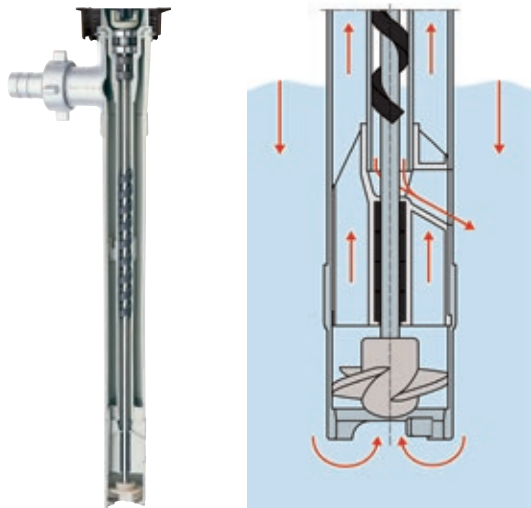

Advantages/characteristics:

- ▶ No seal in liquid zone
- ▶ Particularly suited for hydrochloric acid and chromic acid
- ▶ Spiral-shaped guide-bearing with large guide length
- ▶ Optimum drainage of the inner tube
- ▶ Multiple bearing drive shaft
- ▶ Low wearout of guide-bearing and shaft
- ▶ Long service life
- ▶ No seal wearout
- ▶ Long service life of bearings
- ▶ Temporary operation against closed valve is possible (hand nozzle, ball valve, etc.), up to indicated max. operating temperature
- ▶ Low-vibration
- ▶ Non-ferrous metalfree version to transport AdBlue® available



Technical data/type	F 424 PP	F 424 PVDF	FP 424 Ex S
Seal type	No seal in liquid zone		
Version	With impeller for max. flow rate, with mixed half axial impeller for max. delivery head (Z-version)		
Pressure-side connection	Thread G 1¼ A		
Materials			
Pump	Polypropylene	Polyvinylidene fluoride	Stainless steel 316 Ti
O-ring ²⁾	FKM		
Shaft	Hastelloy C, stainless steel, titanium	Hastelloy C	Stainless steel
Impeller	ETFE		
Dimensions			
Outer tube diameter / Impeller diameter (mm)	41/36 41/35 Z 50/38 50/43 Z	41/36 41/35 Z 50/38	43/38 43/37 Z 50/45 Z
Standard immersion depth	27", 39", 47" (700 mm, 1000 mm, 1200 mm)		
Other immersion depths / special lengths ³⁾	8" - 78" (200 - 2000 mm)		
Operating range			
Container	Drums, IBCs, tanks, canisters, hoboocks, mixing containers etc.		
Media temperature	32 - 122°F (0 - 50°C)	32 - 176°F (0 - 80°C)	32 - 212°F (0 - 100°C)
Media temperature ex-application	-	-	32 - 104°F (0 - 40°C)
Ambient temperature	32 - 104°F (0 - 40°C)	32 - 104°F (0 - 40°C)	-4 - 104°F (-20 - 40°C)
Weight Ø 41, ID 1000 mm	2.2 lbs (1.0 kg)	3.09 lbs (1.4 kg)	-
Weight Ø 43, ID 1000 mm	-	-	6.39 lbs (2.9 kg)
Weight Ø 50, ID 1000 mm	2.86 lb (1.3 kg)	4.19 lbs (1.9 kg)	8.82 lbs (4.0 kg)
Certificates			
Ex-designation	None	None	II 1/2 G c IIB T4
Silicone-free version	On request		
Performance data¹⁾			
	Axial impeller		Half axial impeller (Z-version)
Flow rate max.	63 GPM (240 LPM)		42 GPM (160 LPM)
Delivery head max. mwc	42 ft (13 m)		98 ft (30 m)
Viscosity max.	1200 cPs		1200 cPs

1) Depending on pump version, media and motor

2) For sealing between inner and outer tube (above the fluid level)

3) In gradations of 100 mm

Design, assembly example and dimensions

Drum pumps F/FP 424

Design:

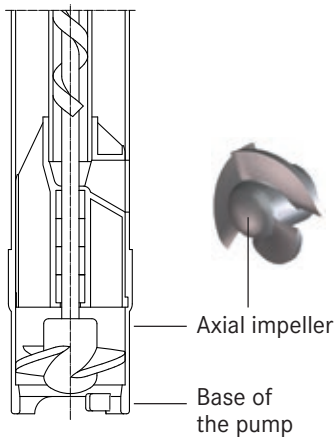

F/FP 424 with guide-bearing and axial impeller

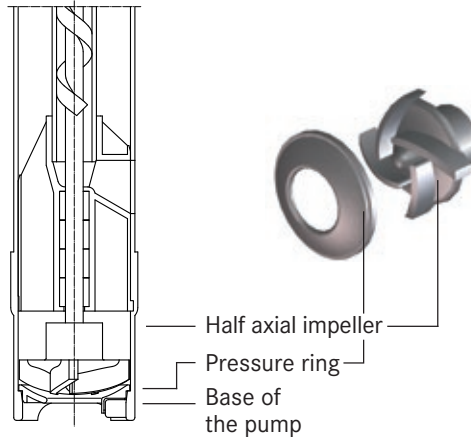

F/FP 424 with guide-bearing and half axial impeller (Z-version)

Assembly example:

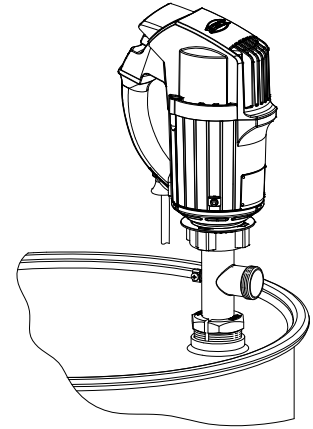

F/FP 424 with compression gland mounted in a drum with bung hole

Dimensions:

Drum pump F/FP 424

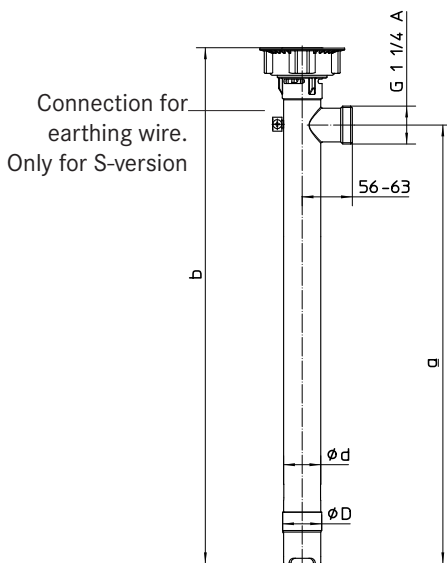

Drum pump with motor

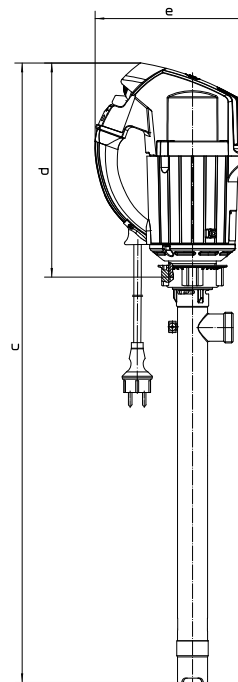

Immersion depths (ID)

Pump material	\emptyset (mm) Outer tube/impeller	ID (mm)	a (mm)	b (mm)
PP / PVDF	41/36 50/38 50/43 Z	700	715	790
		1000	1015	1090
		1200	1215	1290
		Other	ID + 15	ID + 90
		700	707	782
PP / PVDF	41/35 Z	1000	1007	1082
		1200	1207	1182
		Other	ID + 7	ID + 82
		700	695	780
		1000	995	1080
S	43/38 43/37 Z 50/45 Z	1200	1195	1280
		Other	ID - 5	ID + 80

F/FP 424 with motor

Motor type	c (mm)	d (mm)	e (mm)
FEM 4070	b + d - 16	207	186
F 457 (EL)		225	217
F 458 (-1, EL)		292	209
F 460 Ex (-1, EL)		292	209
FBM 4000 Ex		292	209
F 416 Ex		119	230
F 416-1 Ex		101	120
F 416-2 Ex		101	120

Performance diagrams¹⁾

Drum pumps F/FP 424

The following performance diagrams apply to the indicated motors and impellers (36, 38, 35 Z, 37 Z, 43 Z and 45 Z), for all pump materials respectively.

FEM 4070

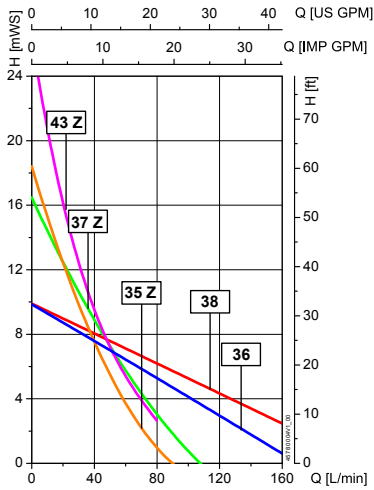

F 457 / F 457 EL

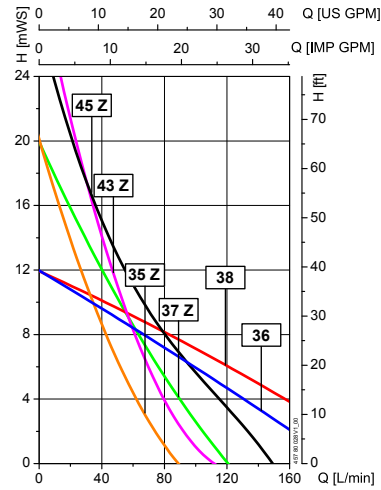

F 458, F 458 EL, F 460 Ex, F 460 Ex EL

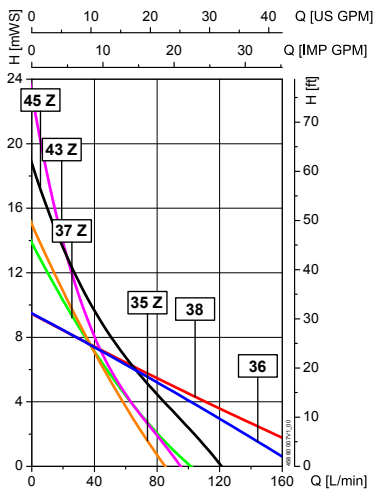

F 458-1 / F 460-1 Ex

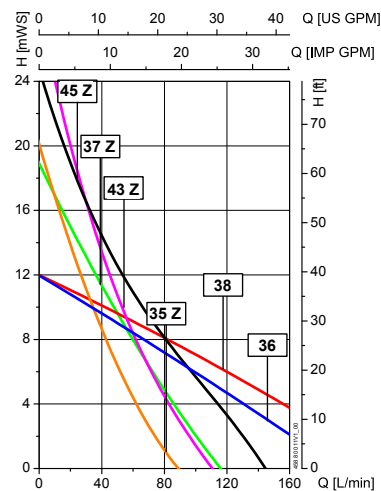

FBM 4000 Ex

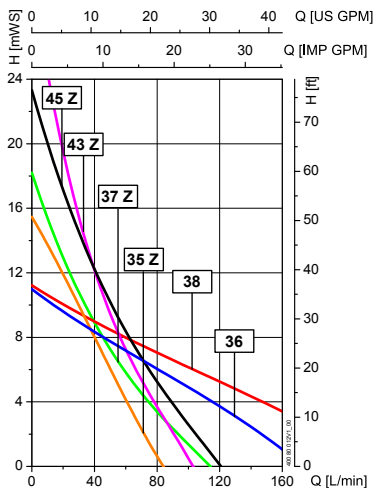

F 416 Ex, F 416-1 Ex, F 416-2 Ex (6 bar)

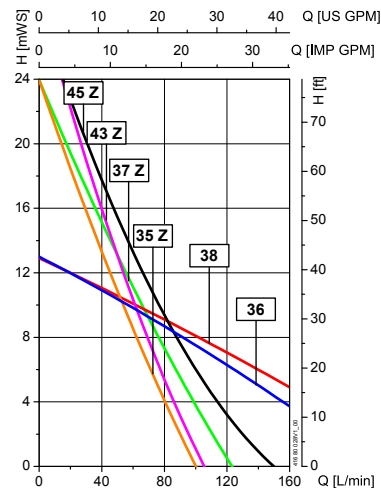

1) Determined with water at 68°F (20°C), measured values ± 10 % maximum flow rate with open discharge outlet

Part numbers

Drum pumps F/FP 424



More than just pumps

Standard immersion depths								
Type	Material			Diameter (mm)		Part no.		
	Pump	Shaft	O-ring ¹⁾	Ø outer tube	Ø impeller	27" (700 mm)	39" (1000 mm)	47" (1200 mm)
F 424 Connection thread G 1 1/4 A	PP	HC	FKM	41	36	424 40 007	424 40 010	424 40 012
			FKM		35 Z	424 40 107	424 40 110	424 40 112
			FKM	50	38	424 40 207	424 40 210	424 40 212
		FKM	43 Z		424 40 307	424 40 310	424 40 312	
		Stainless steel	FKM	41	36	424 40 407	424 40 410	424 40 412
			FKM		35 Z		424 40 510	424 40 512
	PVDF	HC	FKM	41	36	424 40 707	424 40 710	424 40 712
			FKM		35 Z	424 60 007	424 60 010	424 60 012
		FKM	50	38	424 60 207	424 60 210	424 60 212	
				37 Z	424 22 007	424 22 010	424 22 012	
FP 424 Ex Connection thread G 1 1/4 A	S	S	FKM	43	38	424 22 007	424 22 010	424 22 012
			FKM		37 Z	424 22 107	424 22 110	424 22 112
			FEP	43	38	424 29 307	424 29 310	424 29 312
			FEP		37 Z	424 29 407	424 29 410	424 29 412
			FKM	50	45 Z	424 22 207	424 22 210	424 22 212
			FEP		45 Z	424 29 507	424 29 510	424 29 512

Special lengths								
Type	Material			Diameter (mm)		Part no.		
	Pump	Shaft	O-ring ¹⁾	Ø outer tube	Ø impeller	20" (500 mm)	31" (800 mm)	60" (1500 mm)
F 424 Connection thread G 1 1/4 A	PP	HC	FKM	41	36	424 40 005	424 40 008	424 40 015
			FKM		35 Z			424 40 115
		FKM	50	38			424 40 215	
		FKM		41	35 Z		424 40 515	
	Stainless steel	FKM	41	36			424 40 715	
		FKM		41	36		424 60 015	
	PVDF	HC	FKM	41	36		424 60 015	
			FKM		35 Z		424 60 115	
FKM		50	38			424 60 215		
			37 Z	424 22 005		424 22 015		
FP 424 Connection thread G 1 1/4 A	S	S	FKM	43	38	424 22 005		424 22 015
			FKM		37 Z	424 22 105		424 22 115
			FKM	50	45 Z	424 22 205		424 22 215

Other immersion depths/other O-rings/other connections on request

1) For sealing between inner and outer tube (above the fluid level)

Hose connections with union nut G 1 1/4						
Material		Size				
Connection	Union nut	1/2" (DN13)	3/4" (DN19)	1" (DN25)	1-1/4" (DN32)	
Polypropylene (PP)	PP	959 04 081	959 04 053	959 04 052	959 04 054	
Polyvinylidene fluoride (PVDF)	PVDF	959 04 082	959 04 101	959 04 102	959 04 103	
Stainless steel (S) 316 Ti	Brass nickel-plated		959 04 061	959 04 041	959 04 042	
Stainless steel (S) 316 Ti	S		959 04 062	959 04 063	959 04 064	

Accessories

Drum pumps F/FP 424

Accessories for drum pump F/FP 424

Compatible with drum pumps from the F/FP 424 series, we offer a wide selection of accessories, for example, compression glands, hoses, hand nozzles. More information can be found in the FLUX accessory brochure, in the price list or on our homepage: www.fluxcrg.com.

■ for use in hazardous areas

■ for use in hazardous and non hazardous areas

■ for use in non hazardous areas

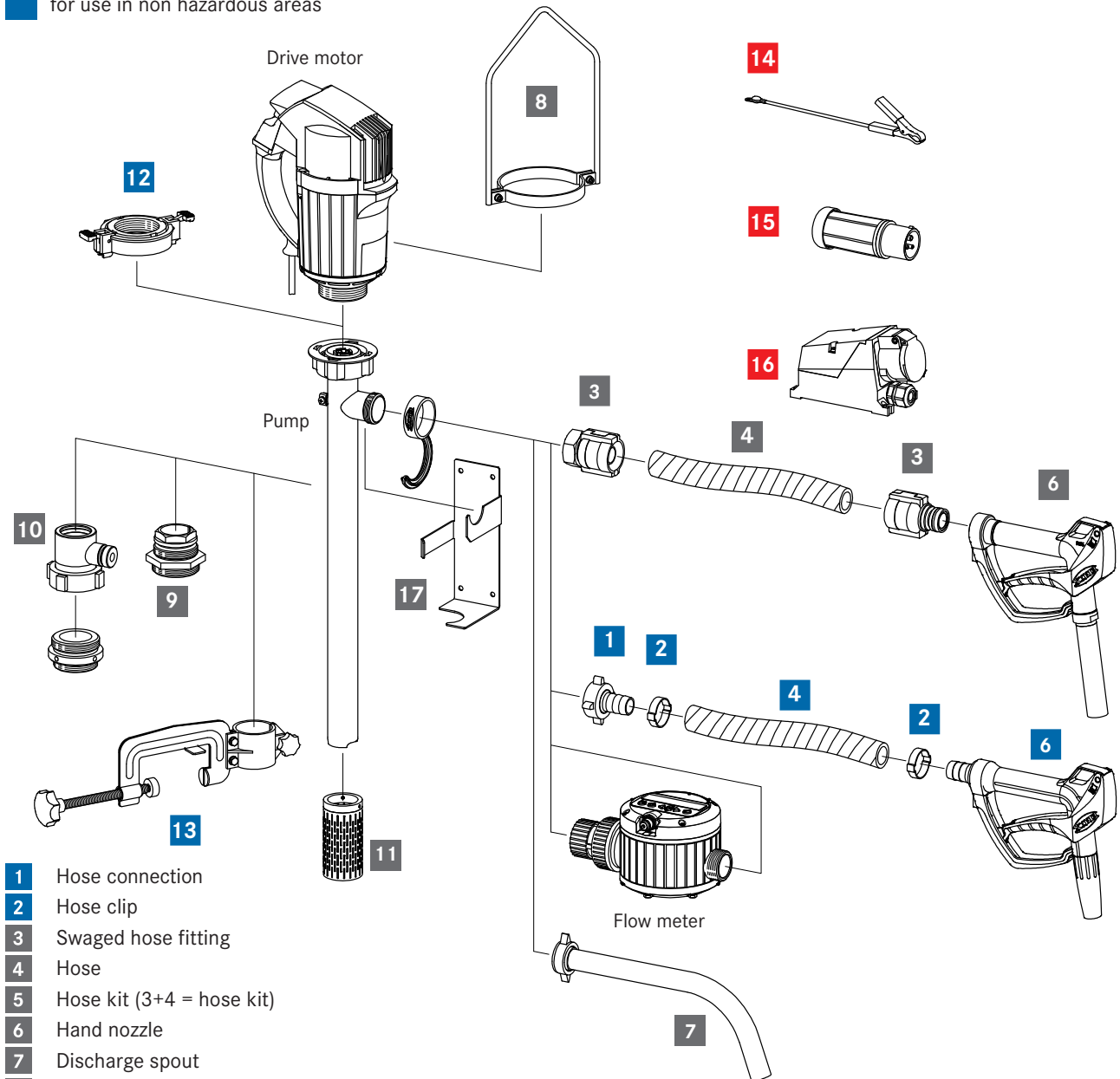

- 1 Hose connection
- 2 Hose clip
- 3 Swaged hose fitting
- 4 Hose
- 5 Hose kit (3+4 = hose kit)
- 6 Hand nozzle
- 7 Discharge spout
- 8 Carrying handle
- 9 Compression gland
- 10 Fume gland
- 11 Suction strainer
- 12 Quick action coupling
- 13 Attachment clamp
- 14 Earth (ground) wire
- 15 Explosion-proof plug
- 16 Explosion-proof socket
- 17 Wall bracket

FLUX PUMPS CORPORATION

300 Townpark Drive, Suite 110
 Kennesaw, GA 30144, USA
 Phone 800-367-3589
info@fluxpumpsusa.com
www.fluxpumpsusa.com