

Technical Data Sheet

Drum pumps F/FP 430



More than just pumps

Drum pumps F/FP 430

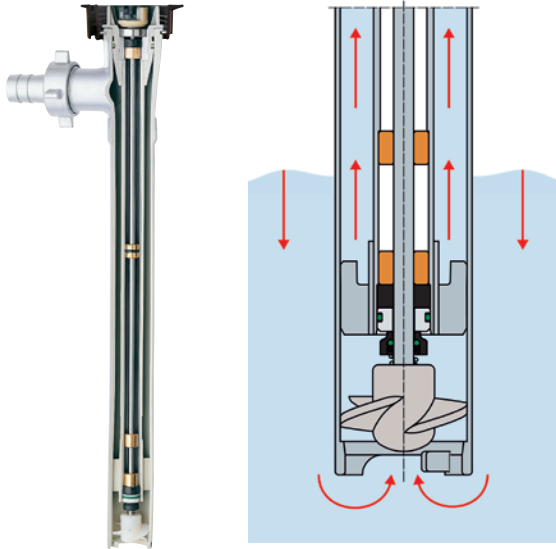

Advantages/characteristics:

- ▶ With mechanical seal for interior seal
- ▶ Compared to sealless pump increased service life with abrasive media
- ▶ Ideal for frequent media changes, curing media, quick drying media, crystallising media
- ▶ Can be easily dismantled into two parts for cleaning
- ▶ With metal core reinforced inner tube on plastic versions, prevents leakage and unnecessary wearout of the mechanical seal at all application temperature areas
- ▶ Operation against closed valve is possible (hand nozzle, ball valve, etc.), up to indicated max. operating temperature



Technical data/type	F 430 PP	F 430 PVDF	F 430 S	FP 430 S FOOD	F 430 HC	F 430 AI
Seal type	Mechanical seal					
Version	With impeller for max. flow rate, with mixed half axial impeller for max. delivery head (Z-version)					
Pressure-side connection	Thread G 1 1/4 A		Clamp 1 1/2"		Thread G 1 1/4 A	
Materials						
Pump	Polypropylene	Polyvinylidene fluoride	Stainless steel 316 Ti		Hastelloy C	Aluminium
O-ring ²⁾	EPDM, FKM	FKM, FFKM	EPDM, FKM, FFKM	FKM	FFKM	NBR
Mechanical seal	Oxide ceramics, PTFE/coal					
Shaft	Hastelloy C		Stainless steel 316 Ti		Hastelloy C	Stainless steel
Impeller	ETFE			Stainless steel	ETFE	
Dimensions						
Outer tube diameter / Impeller diameter (mm)	40/33 40/33 Z 50/38 50/43 Z		41/38 41/37 Z 50/45 Z		41/38	40/38
Standard immersion depth	27", 39", 47" (700 mm, 1000 mm, 1200 mm)					
Other immersion depths / special lengths ³⁾	8" - 118" (200 - 3000 mm)					8" - 78" (200 - 2000 mm)
Operating range						
Container	Drums, IBCs, tanks, canisters, hobbocks, mixing containers etc.					
Media temperature	32 - 122°F (0 - 50°C)	32 - 176°F (0 - 80°C)	32 - 212°F (0 - 100°C)		32 - 248°F (0 - 120°C)	32 - 176°F (0 - 80°C)
Media temperature ex-application	-		32 - 104°F (0 - 40°C)		-	
Ambient temperature	32 - 104°F (0 - 40°C)		-4 - 104°F (-20 - 40°C)			
Weight Ø 40/41, ID 1000 mm	3.09 lbs (1.4 kg)	3.75 lbs (1.7 kg)	6.61 lbs (3.0 kg)	6.61 lbs (3.0 kg)	6.61 lbs (3.0 kg)	3.31 lbs (1.5 kg)
Weight Ø 50, ID 700/1000/1200 mm	3.31 lbs (1.5 kg)	4.63 lbs (2.1 kg)	9.92 lbs (4.5 kg)	-	-	3.97 lbs (1.8 kg)
Certificates						
Ex-identification	None	None	II 1/2 G IIB T4		None	
Food approvals	None	None	None	(EG) 935/2004 FDA CFR 21	None	None
Silicone-free version	On request					
Performance data¹⁾						
	Impeller			Half axial impeller (Z-version)		
Flow rate max.	63 GPM (240 LPM)			31 GPM (120 LPM)		
Delivery head max.	39 ft (12 m)			91 ft (28 m)		
Viscosity max.	1000 cPs			1200 cPs		

1) Depending on pump version, media and motor

2) Other materials available on request

3) In gradations of 100 mm

Design, assembly example and dimensions

Drum pumps F/FP 430

Design:

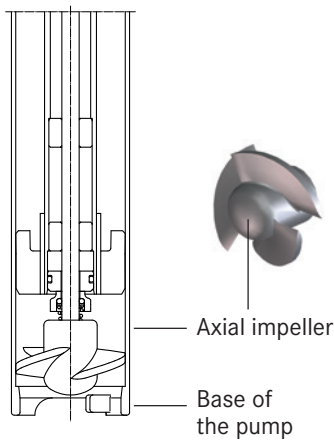

F/FP 430 with mechanical seal and impeller

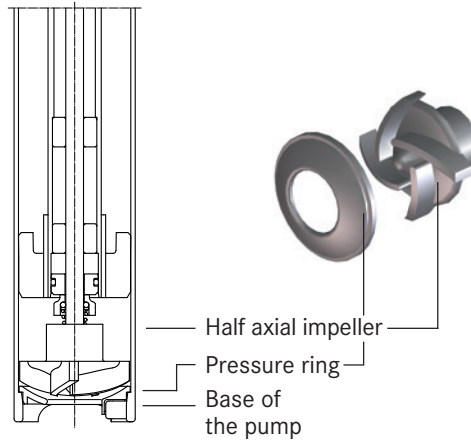

F/FP 430 with mechanical seal and half axial impeller (Z-version)

Assembly example:

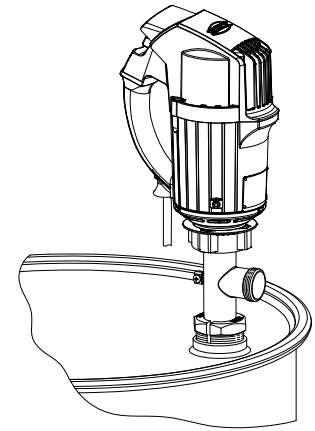

F/FP 430 with compression gland joint mounted in a drum with bung hole

Dimensions:

Drum pump F/FP 430

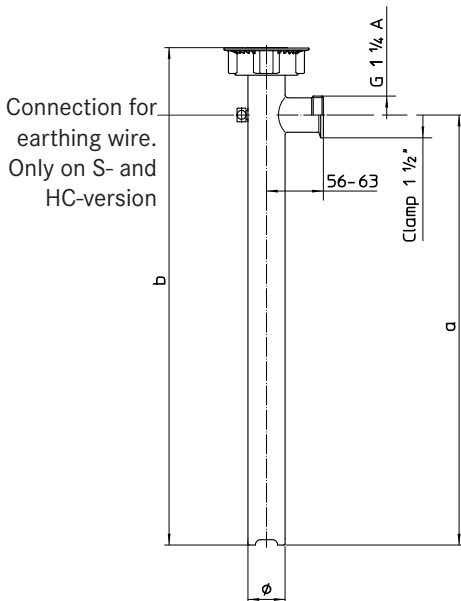

Drum pump with motor

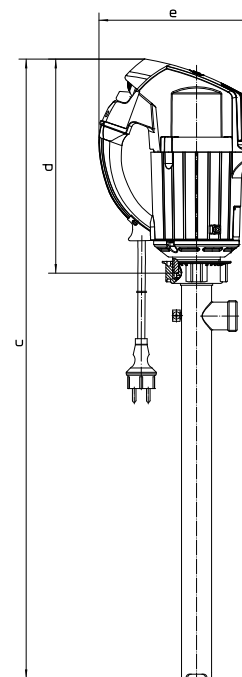

Standard immersion depth (ID)

Ø (mm)	ID (mm)	a (mm)	b (mm)
40/41 or 50	700	706	780
	1000	1006	1080
	1200	1206	1280

Other immersion depths (ID)

a = ID + 6 and b = ID + 80

F/FP 430 with motor

Motor type	c (mm)	d (mm)	e (mm)
FEM 4070	b + d - 16	207	186
F 457 (EL)		225	217
F 458 (-1, EL)		292	209
F 460 Ex (-1, EL)		292	209
FBM 4000 Ex		292	209
F 416 Ex		119	230
F 416-1 Ex		101	120
F 416-2 Ex		101	120

Performance diagrams¹⁾

Drum pumps F/FP 430

The following performance diagrams apply to the indicated motors and impellers (33, 38, 33 Z, 37 Z, 43 Z and 45 Z), for all pump materials respectively.

FEM 4070

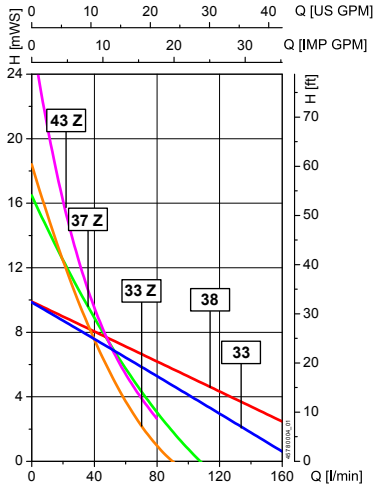

F 457 / F 457 EL

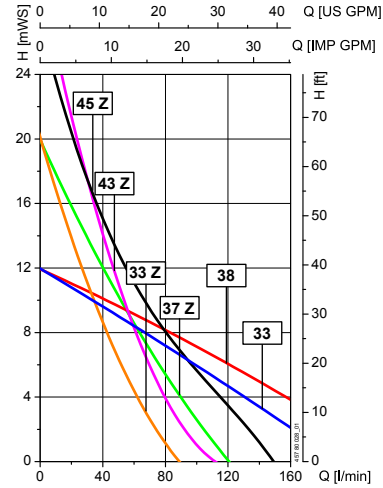

F 458, F 458 EL, F 460 Ex, F 460 Ex EL

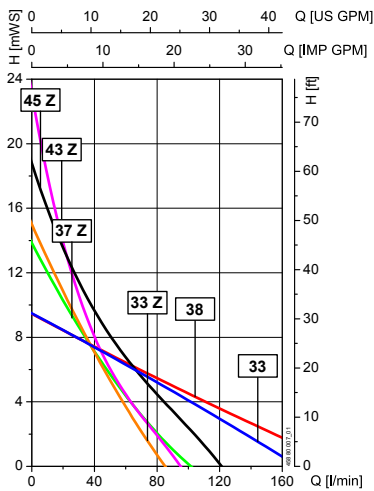

F 458-1 / F 460-1 Ex

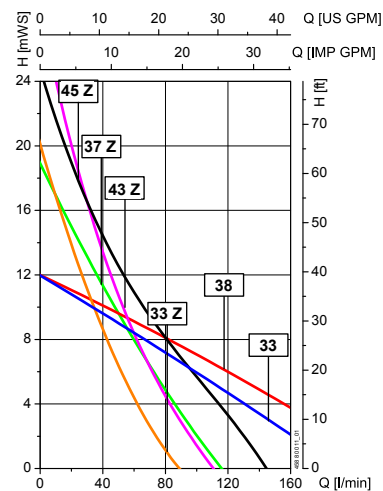

FBM 4000 Ex

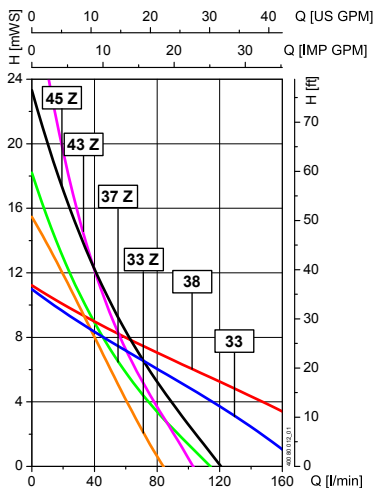

F 416 Ex, F 416-1 Ex, F 416-2 Ex (6 bar)

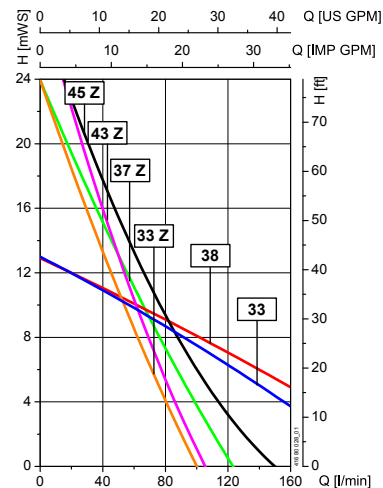

1) Determined with water at 68°F (20°C), measured values ± 10 % maximum flow rate with open discharge outlet

Part numbers

Drum pumps F/FP 430



More than just pumps

Standard immersion depths								
Type	Material			Diameter (mm)		Part no.		
	Pump	Shaft in contact with medium	O-ring	Ø outer tube	Ø impeller	27" (700 mm)	39" (1000 mm)	47" (1200 mm)
F 430 Connection thread G 1 1/4 A	PP	HC	FKM	40	33	430 40 107	430 40 110	430 40 112
			EPDM					
			FKM	50	33 Z	430 40 407	430 40 410	430 40 412
			FKM					
	PVDF	HC	FKM	40	33	430 40 207	430 40 210	430 40 212
			FFKM					
			FKM	50	33 Z	430 60 107	430 60 110	430 60 112
			FKM					
			FKM	50	38	430 60 307	430 60 310	430 60 312
			FKM					
	AI	S	NBR	41	38	430 10 107	430 10 110	430 10 112
			NBR					
			NBR	50	38	430 10 407	430 10 410	430 10 412
	NBR							
	HC	HC	FFKM	40	38	430 10 307	430 10 310	430 10 312
			FFKM					
	S	S	FKM	41	38	430 20 107	430 20 110	430 20 112
			EPDM					
			FFKM	50	37 Z	430 20 207	430 20 210	430 20 212
			FKM					
FP 430 Ex FOOD Connection thread clamp 1 1/2"	S	S	FKM	41	38	430 20 507	430 20 510	430 20 512

Special lengths								
Type	Material			Diameter (mm)		Part no.		
	Pump	Shaft in contact with medium	O-ring	Ø outer tube	Ø impeller	20" (500 mm)	60" (1500 mm)	71" (1800 mm)
F 430 Connection thread G 1 1/4 A	PP	HC	FKM	40	33	430 40 105	430 40 115	430 40 118
			FKM					
			FKM	50	33 Z	430 40 405	430 40 415	430 40 418
			FKM					
	PVDF	HC	FKM	40	33	430 40 305	430 40 315	430 40 318
			FKM					
			FKM	50	33 Z	430 40 205	430 40 215	430 40 218
			FKM					
			FKM	50	38	430 60 105	430 60 115	430 60 118
			FKM					
	FKM	50	38	430 60 405	430 60 415	430 60 418		
	FKM							
	AI	S	NBR	41	38	430 60 305	430 60 315	430 60 318
			NBR					
	S	S	FKM	41	38	430 10 105	430 10 115	430 10 118
			FKM					
FKM			50	37 Z	430 10 405	430 10 415	430 10 418	
FKM								
FKM	50	45 Z	430 20 105	430 20 115	430 20 118			
FKM								
FKM	50	37 Z	430 20 405	430 20 415	430 20 418			
FKM								
FKM	50	45 Z	430 20 205	430 20 215	430 20 218			
FKM								

Special lengths								
Type	Material			Diameter (mm)		Part no.		
	Pump	Shaft in contact with medium	O-ring	Ø outer tube	Ø impeller	79" (2000 mm)	98" (2500 mm)	118" (3000 mm)
F 430 Connection thread G 1 1/4 A	PP	HC	FKM	40	33	430 40 120		
			FKM					
			FKM	50	33 Z	430 40 420		
			FKM					
	PVDF	HC	FKM	40	33	430 40 320	430 40 325	430 40 330
			FKM					
			FKM	50	33 Z	430 40 220	430 40 225	430 40 230
			FKM					
			FKM	50	38	430 60 120	430 60 125	430 60 130
			FKM					
	FKM	50	38	430 60 320	430 60 325	430 60 330		
	FKM							
	FKM	50	38	430 60 220	430 60 225	430 60 230		
	FKM							
	AI	S	NBR	41	38	430 10 120		
			NBR					
S	S	FKM	41	38	430 10 420			
		FKM						
		FKM	50	37 Z	430 20 120	430 20 125	430 20 130	
		FKM						
FKM	50	45 Z	430 20 420	430 20 425	430 20 430			
FKM								
FKM	50	45 Z	430 20 220	430 20 225	430 20 230			
FKM								

Other immersion depths/other O-rings/other connections on request

Hose connections with union nut G 1 1/4 for standard version					
Material		Size			
Connection	Union nut	1/2" (DN13)	3/4" (DN19)	1" (DN25)	1-1/4" (DN32)
Polypropylene (PP)	PP	959 04 081	959 04 053	959 04 052	959 04 054
Polyvinylidene fluoride (PVDF)	PVDF	959 04 082	959 04 101	959 04 102	959 04 103
Aluminium (Al)	Brass nickel-plated		959 04 050	959 04 039	959 04 040
Hastelloy C (HC)	S			959 04 043	959 04 044
Stainless steel (S) 316 Ti	Brass nickel-plated		959 04 061	959 04 041	959 04 042
Stainless steel (S) 316 Ti	S		959 04 062	959 04 063	959 04 064

Hose connections with clamp 1 1/2" for FOOD-version					
Material		Size			
Connection	Seal	3/4" (DN19)	1" (DN25)		
Stainless steel (S) 316 Ti	FKM	959 04 171	959 04 169		
	NBR	960 04 172	960 04 170		

Accessories

Drum pumps F/FP 430

Accessories for drum pump F/FP 430

Compatible with drum pumps from the F/FP 430 series, we offer a wide selection of accessories, for example, compression glands, hoses, hand nozzles. More information can be found in the FLUX accessory brochure, in the price list or on our homepage: www.fluxcrg.com.

- for use in hazardous areas
- for use in non hazardous areas

for use in hazardous and non hazardous areas

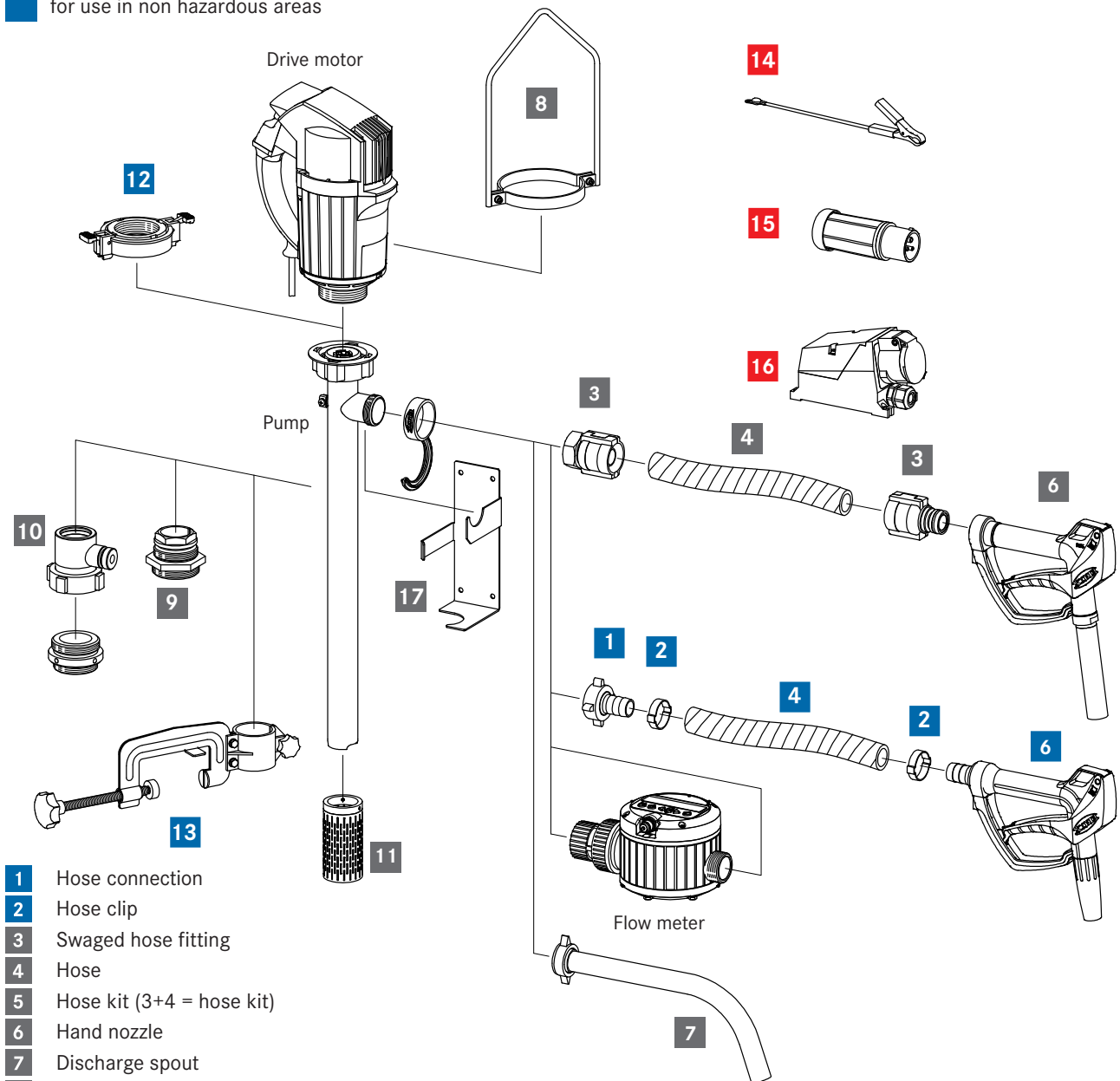

- 1 Hose connection
- 2 Hose clip
- 3 Swaged hose fitting
- 4 Hose
- 5 Hose kit (3+4 = hose kit)
- 6 Hand nozzle
- 7 Discharge spout
- 8 Carrying handle
- 9 Compression gland
- 10 Fume gland
- 11 Suction strainer
- 12 Quick action coupling
- 13 Attachment clamp
- 14 Earth (ground) wire
- 15 Explosion-proof plug
- 16 Explosion-proof socket
- 17 Wall bracket

FLUX PUMPS CORPORATION
 300 Townpark Drive, Suite 110
 Kennesaw, GA 30144, USA
 Phone 800-367-3589
info@fluxpumpsusa.com
www.fluxpumpsusa.com