

Overview of FLUX Accessories

For 4 Series Stainless Steel Drum & Container Pumps

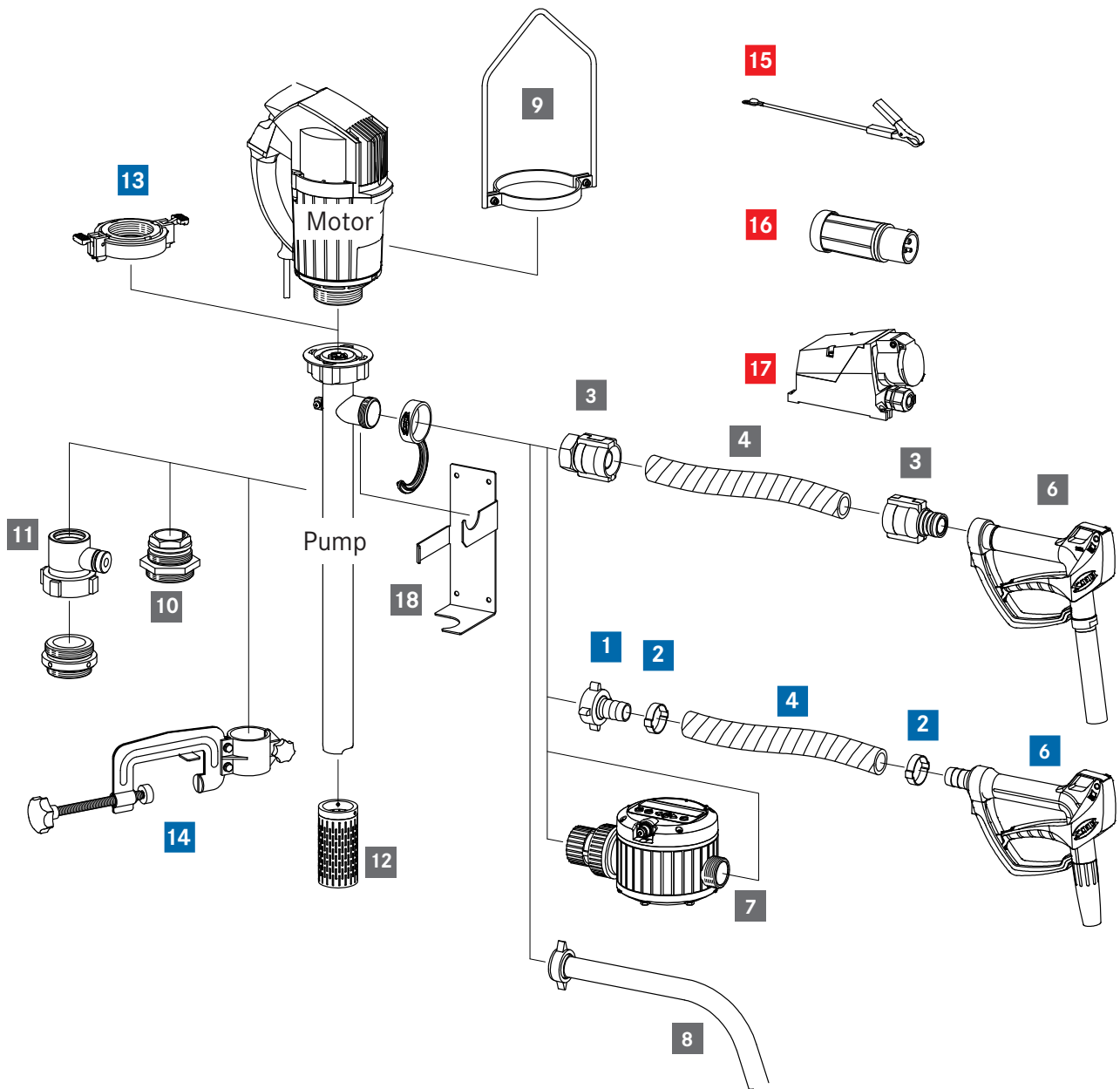

More than just pumps



- 1** Hose connection
- 2** Hose clip
- 3** Swaged hose fitting
- 4** Hose
- 5** Hose kit (3+4 = hose kit)
- 6** Hand nozzle

- 7** Flow meters
- 8** Discharge spout
- 9** Carrying handle
- 10** Compression gland
- 11** FLUX fume gland
- 12** Suction strainer

- 13** Quick action coupling
- 14** Attachment clamp
- 15** Earth (ground) wire
- 16** Explosion-proof plug
- 17** Explosion-proof socket
- 18** Wall bracket

■ Safe for use in hazardous areas

■ Not for use in hazardous areas

■ Safe for use in both hazardous and non-hazardous areas













FLUX PUMPS CORPORATION
 300 Townpark Drive, Suite 130
 Kennesaw, GA 30144, USA
 Phone 800-367-3589
 info@fluxpumpsusa.com
 www.fluxpumpsusa.com

Overview of FLUX Accessories

For 4 Series Stainless Steel Drum & Container Pumps



More than just pumps

Map Key	Part Number	Description	
1	959.04.061	3/4" Hose Barb Connection	
	959.04.041	1" Hose Barb Connection	
	959.04.042	1-1/4" Hose Barb Connection	
2	959.13.241	3/4" Hose Clamp	
	959.13.243	1" Hose Clamp	
	959.13.248	1-1/4" Hose Clamp	
4	001.10.838	7/8" Universal Hose (sold per meter)	
	001.10.870	Universal Hose Assembly, 2M, w/Fittings	
	001.10.871	Universal Hose Assembly, 3M, w/Fittings	
6	001.12.541	3/4" Hand Nozzle, PTFE/FEP elastomers	
	001.12.542	1" Hand Nozzle, PTFE/FEP elastomers	
	001.12.549	Hand Nozzle, PTFE/FEP elastomers, (For use with hose assemblies above)	
7	A0400029	FMC 100, Stainless Steel, EPDM elastomers	
	A0400031	FMC 100, Stainless Steel, FKM elastomers	
	A0400033	FMC 100, Stainless Steel, FFKM elastomers	
8	959.07.007	Discharge Spout, Stainless Steel	
9	001.10.533	Carrying Handle, F457	
	001.10.557	Carrying Handle, F458, F460, FBM4000Ex	
10	001.14.061	Compression Gland, SS, 40mm	
	001.14.000	Compression Gland, SS, 41mm	
	001.14.003	Compression Gland, SS, 50mm	
11	001.14.181	Fume Gland, SS, Upper Valve, 41mm	
	001.14.182	Fume Gland, SS, Upper Valve, 50mm	
	001.14.325	Fume Gland, SS, Lower Ring, G2, 41mm	
	001.14.331	Fume Gland, SS, Lower Ring, G2, 50mm	
12	001.10.200	Suction Strainer, SS, 41mm	
	001.10.205	Suction Strainer, SS, 43mm	
	001.10.212	Suction Strainer, SS, 50mm	
13	001.10.802	Quick Action Coupling, SSK	
14	001.10.601	Attachment Clamp, Steel/Zinc Plated, 40/41mm	
	001.10.603	Attachment Clamp, Steel/Zinc Plated, 50mm	
18	001.10.426	Wall Bracket	