

JUNIORFLUX/COMBIFLUX

For transferring smaller quantities



We deliver values.



JUNIORFLUX/COMBIFLUX

For transferring smaller quantities

The small drum pumps JUNIORFLUX and COMBIFLUX are especially suitable for pumping comparably small quantities out of containers such as canisters or drums of up to 200 litres. The small outer tube diameter allows pumping even out of narrow openings.

JUNIORFLUX F 310
(see page 4)



JUNIORFLUX F 314
(see page 4)



JUNIORFLUX

The JUNIORFLUX drum pump unit with its fixed motor FEM 3070 is available with mechanical seal (F 310) and as a sealless type (F 314).

Technical data		
Pump	F 310	F 314
Seal type	with mechanical seal	sealless
Outer tube materials	PP	PP, PVDF, S
Outside diameter in mm	25, 32	25, 32 (PP) 25 (PVDF) 28 (S)
Immersion length	500/700/1,000 mm	
Viscosity max.	250 mPas	
Motor	FEM 3070	
Delivery rate*	max. 47 l/min	max. 57 l/min
Delivery head*	max. 6,8 mWs	max. 8,5 mWs

FEM 3070
(see page 5)



FBM-B 3100
(see page 6)



**COMBIFLUX
pump FP 314**

COMBIFLUX

The small sealless drum pump COMBIFLUX FP 314 can be combined with the collector motor FEM 3070 (with mains connection) or with the battery motor FBM-B 3100.

Technical data		
Pump	FP 314	
Seal type	sealless	
Outer tube materials	PP, PVDF, S	
Outside diameter in mm	25, 32 (PP) 25 (PVDF) 28 (S)	
Immersion length	500/700/1,000 mm	
Viscosity max.	250 mPas	
Motor	FEM 3070	FBM-B 3100
Delivery rate*	max. 57 l/min	max. 60 l/min
Delivery head*	max. 8,5 mWs	max. 7 mWs

* measured at pump discharge with water (20 °C) depending on outer tube material.

Drum pumps F 310 and F 314/FP 314

with small outer tube diameter



The drum pumps F 310 and F 314/FP 314 are characterised by their small outer tube diameters. This makes these axially acting rotary pumps e.g. especially suitable for pumping out of small and narrow-necked containers.

F 310 – The small drum pump with mechanical seal

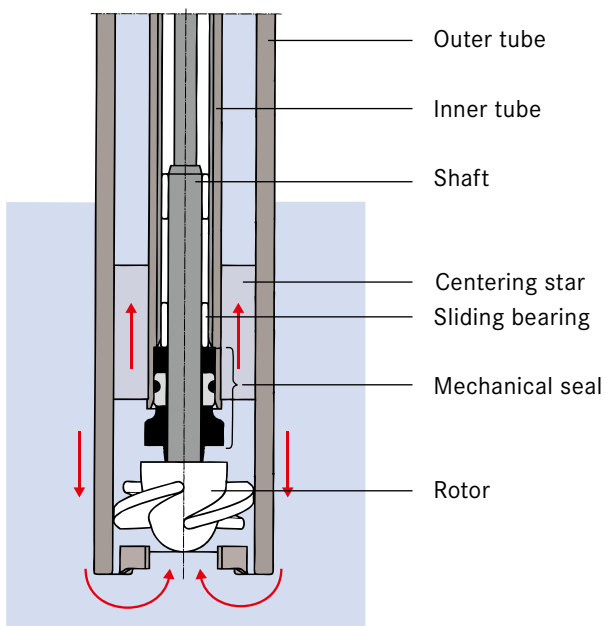

Description

The mechanical seal of the F 310 seals the inner tube against the media. In this way, the seal prevents the fluid from getting into the inner tube.

Product features

- ▶ With mechanical seal
- ▶ Small outer tube diameter
- ▶ Low weight

Examples of media

- ▶ Acids and lyes
- ▶ Fertiliser solutions
- ▶ Cleaning agent solutions
- ▶ Water

Technical data

- ▶ Outside Ø: 25 mm, 32 mm
- ▶ Outer tube materials: polypropylene, polyvinylidene fluoride, stainless steel
- ▶ Max. viscosity: 250 mPas
- ▶ Max. delivery rate: 47 litres/min
- ▶ Max. delivery head: 6.8 mWs

F 314/FP 314 – The small sealless drum pump

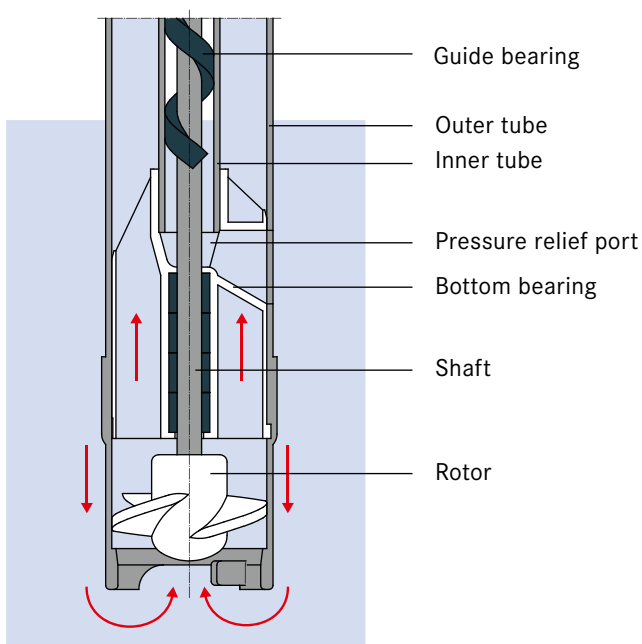

Description

In the sealless F 314/FP 314, the rotor transports the media along the shaft also into the inner tube where it has the same level as in the container.

During emptying, the media flows off through the relief openings.

Product features

- ▶ Without mechanical seal
- ▶ Small outer tube diameter
- ▶ Low weight

Examples of media

- ▶ Also corrosive fluids such as concentrated nitric acid, sulphuric acid, acetic acid

Technical data

- ▶ Outside Ø: 25 mm, 28 mm, 32 mm
- ▶ Outer tube materials: polypropylene, polyvinylidene fluoride, stainless steel
- ▶ Max. viscosity: 250 mPas
- ▶ Max. delivery rate: 60 litres/min
- ▶ Max. delivery head: 8.5 mWs

JUNIORFLUX

with fixed collector motor FEM 3070

The small drum pump JUNIORFLUX with its fixed collector motor is available with a mechanical seal (F 310) and as a sealless version (F 314). It is especially suitable for pumping comparably small quantities out of containers such as canisters or drums of up to 200 litres. The small outer tube diameter allows pumping even out of narrow openings.

JUNIORFLUX F 310 PP



Transferring of small quantities with the JUNIORFLUX pump kit.

* measured at pump discharge with water (20 °C) depending on outer tube material.

Product features

- ▶ With mains connection
- ▶ Powerful collector motor (with brushes)
- ▶ Available in two seal types
- ▶ Ergonomic design handle
- ▶ Low weight
- ▶ Small outer tube diameter
- ▶ Holding hook for hand nozzle at the pump discharge
- ▶ With integrated holder for the pump
- ▶ Also available as a pump kit

Advantages

- ▶ Also suitable for transferring smaller quantities
- ▶ Can pump out of narrow-necked containers
- ▶ Minimal force required to change drums
- ▶ With mains connection – enables very long operating times
- ▶ High operational safety due to overload cut-out switch
- ▶ Easy single-hand operation
- ▶ Hand nozzle always quickly at hand due to holding hook
- ▶ Low storage space required

Technical data

Pump:

- ▶ Seal type: F 310 with mechanical seal (see page 3 for more)
F 314 sealless (see page 3 for more)
- ▶ F 310 outer tube material: polypropylene
- ▶ F 314 outer tube materials: polypropylene/ polyvinylidene fluoride/stainless steel
- ▶ Delivery rate: 17 - 57 l/min*
- ▶ Max. viscosity: 250 mPas
- ▶ Max. delivery head: 8.5 mWs
- ▶ Immersion length: 500/700/1,000 mm
- ▶ Pump discharge connection
- ▶ Outside diameter: 25 - 32 mm (depending on media)

Motor FEM 3070:

- ▶ Type: Collector motor
- ▶ Protection class: IP 24
- ▶ Speed adjustment: 2 steps
- ▶ Weight: 1.5 kg
- ▶ Voltage: 110 V, 50 - 60 Hz; 240, 230 V, 50 Hz
- ▶ 230 V version tested to German VDE and GS
- ▶ 5 m cable with 2-pole connector (cables and connectors specific to country)

COMBIFLUX

with removable collector motor FEM 3070



The small sealless drum pump COMBIFLUX FP 314 can be combined with the collector motor FEM 3070 (with mains connection). It is of a modular design, so that several pumps can be operated in series with one motor. Like the JUNIORFLUX, the COMBIFLUX is especially suitable for pumping comparably small quantities out of containers such as canisters or drums of up to 200 litres. The small outer tube diameter allows pumping even out of narrow openings.

COMBIFLUX with FEM 3070

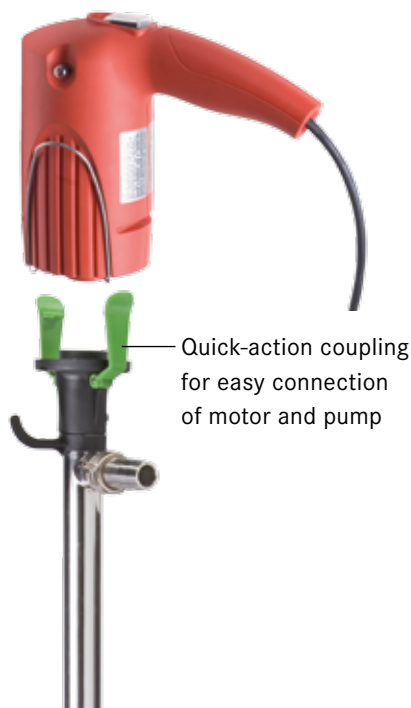

Product features

- ▶ Collector motor and pump connected by means of quick-action coupling
- ▶ With mains connection
- ▶ Powerful collector motor (with brushes)
- ▶ Ergonomic design handle
- ▶ Small outer tube diameter
- ▶ Low overall weight
- ▶ Holding hook for hand nozzle at the pump discharge
- ▶ With integrated holder for the pump

Advantages

- ▶ **Motor easily removable**
- ▶ **Several pumps can be operated in series with one motor**
- ▶ **Also suitable for transferring smaller quantities**
- ▶ **Enables pumping out of narrow-necked containers difficult to access**
- ▶ **Minimal force required to change drums**
- ▶ **Easy single-hand operation**
- ▶ **With mains connection – enables very long operating times**
- ▶ **High operational safety due to overload cut-out switch**
- ▶ **Hand nozzle always quickly at hand due to holding hook**
- ▶ **Low storage space required**



COMBIFLUX – Transferring of various fluids with several pumps and a tethered motor FEM 3070.

Technical data

Pump FP 314 (see page 3 for more):

- ▶ Outer tube materials: polypropylene/ polyvinylidene fluoride/stainless steel
- ▶ Delivery rate: 27 - 57 l/min*
- ▶ Max. viscosity: 250 mPas
- ▶ Max. delivery head: 8.5 mWs
- ▶ Immersion length: 500/700/1,000 mm
- ▶ Pump discharge connection
- ▶ Outside diameter: 25 - 32 mm (depending on media)

Motor FEM 3070:

- ▶ Type: collector motor
- ▶ Protection class: IP 24
- ▶ Speed adjustment: 2 steps
- ▶ Weight: 1.5 kg
- ▶ Voltage: 110 V, 50 - 60 Hz; 230 V, 50 - 60 Hz
- ▶ 5 m cable with 2-pole connector (cables and connectors specific to country)

* measured at pump discharge with water (20 °C) depending on outer tube material.

COMBIFLUX

with removable battery motor FBM-B 3100

The small sealless drum pump COMBIFLUX FP 314 can also be operated with the new battery motor FBM-B 3100, the world's first maintenance-free battery motor for pumps. In this combination, the pump impresses with its high delivery rate astonishing for such a small pump. The long battery service life and extremely short charging time of the new motor's replaceable storage battery are convincing. It is especially suitable for applications where cables are problematic or not desired, or where there is no mains supply at all, e.g. outdoors.

COMBIFLUX with FBM-B 3100



Product features

- ▶ No mains connection required
- ▶ Brushless motor
- ▶ Motor with quickly replaceable storage battery
- ▶ Powerful storage battery
- ▶ Very short charging times
- ▶ Constant speed over entire battery service life
- ▶ Battery motor and pump connected by means of quick-action coupling
- ▶ Ergonomic design motor handle
- ▶ Small outer tube diameter
- ▶ Low overall weight

Advantages

- ▶ Can be used immediately and flexibly – without installing cables, independent of power outlets – also outdoors
- ▶ Maintenance-free and wear-free – saves costs
- ▶ A 200-litre drum can be emptied within just three minutes (at 15,000 rpm)
- ▶ Battery runtime up to 120 min
- ▶ Ten 200-litre drums can be emptied with one storage battery (at 5,000 rpm)
- ▶ Delivery rate will not drop near end of battery service life
- ▶ Last speed setting active when switched on again
- ▶ Minimal interruption of work due to replaceable storage battery
- ▶ Replaceable storage battery – recharged within 30 minutes
- ▶ Motor easily removable
- ▶ Several pumps can be operated in series with one motor
- ▶ Also suitable for transferring smaller quantities
- ▶ Enables pumping out of narrow-necked containers difficult to access



FBM-B 3100 battery motor – the solution where cables are problematic or not desired.



High mobility due to battery motor.

Technical data

Pump FP 314 (see page 3 for more):

- ▶ Type of seal: sealless
- ▶ Outer tube materials: polypropylene/
polyvinylidene fluoride/stainless steel
- ▶ Delivery rate: 12 - 60 l/min*
- ▶ Max. viscosity: 250 mPas
- ▶ Delivery head: 7 mWs
- ▶ Immersion length: 500/700/1,000 mm
- ▶ Outside diameter: 25 - 32 mm (depending on media)



Variable delivery rate due to stepless speed adjustment.



Minimal interruption of work due to replaceable battery.

Motor FBM-B 3100:

- ▶ Type: brushless d.c. motor
- ▶ Drive: battery
- ▶ Protection class: IP 44
- ▶ Speed adjustment: infinitely variable
- ▶ Weight: 1.2 kg

Battery + charger:

- ▶ Battery type: lithium-ion
- ▶ Battery voltage: 18 V
- ▶ Battery capacity: 1.5 Ah
- ▶ Charger: 100 - 120 V, 50 - 60 Hz; 220 - 240 V, 50 - 60 Hz
- ▶ Type: fast charger
- ▶ Charging time: 30 min



Fully recharged within 30 minutes.

* measured at pump discharge with water (20 °C)
depending on type of pump.



We deliver values.

FLUX has become a world renowned brand name for the highest standards in pump technology. It all began in 1950 when the electric drum pump was invented. Today, our wide range of products includes drum and container pumps, centrifugal immersion pumps, eccentric worm-drive pumps, drum-emptying systems and air-operated diaphragm pumps as well as mixers, flow meters and, of course, an extensive range of accessories.

Apart from the outstanding quality of our FLUX products, our customers appreciate our staff's great expertise and real customer orientation.

Put us to the test. We are looking forward to hearing from you.

